

REVISIONS				
ZONE	REV	DESCRIPTION	DATE	APPROVED
	1			
	2			
	3			

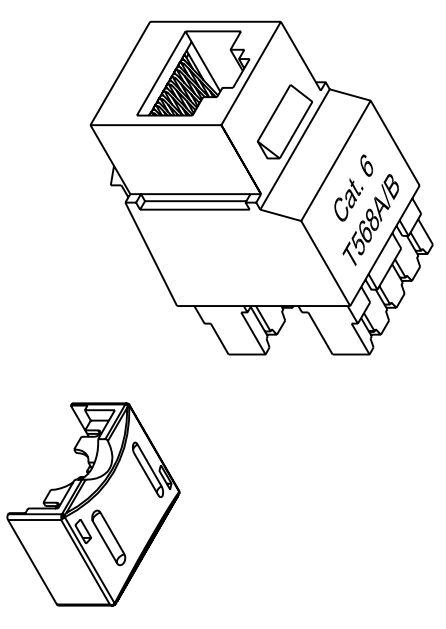

**SUGGESTED PANEL CUTOUT**

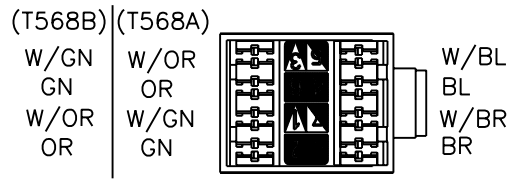
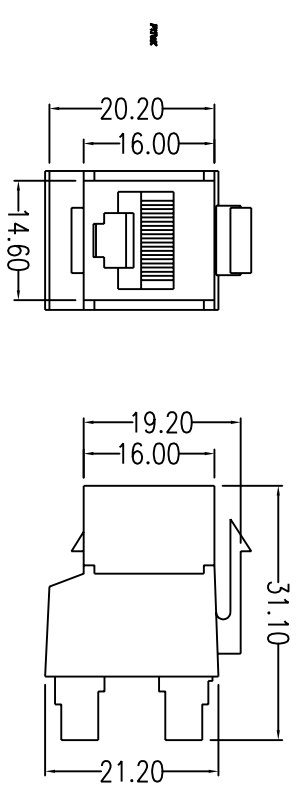
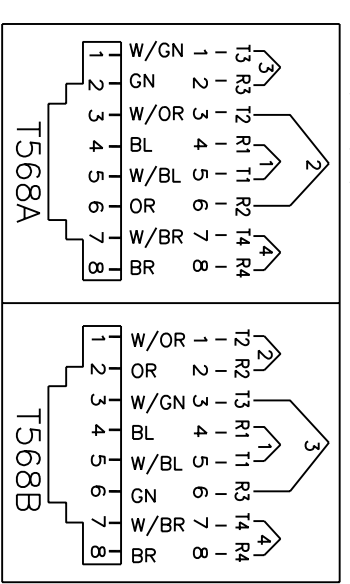
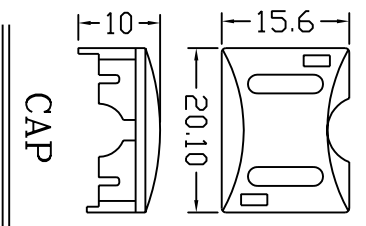
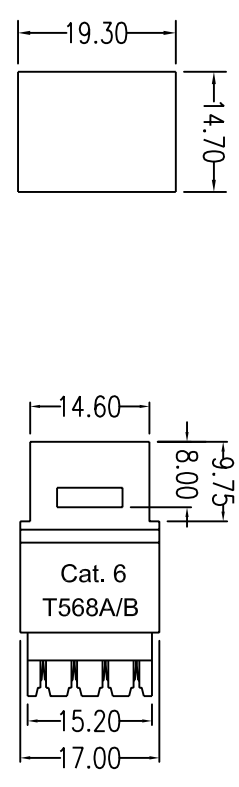

**Cat 6**  
**UL CERTIFIED**  
 ACCORDING TO TIA/EIA-568-B-2-1  
 REQUIREMENTS  
 FILE NO.E145249

**MATERIAL**  
 Housing: ABS, UL 94V-0  
 IDC plastic: PC, UL 94V-0  
 IDC contact: Phosphor Bronze with 200u  
 " Tin over 100u" Nickel undercoat  
 Spring Wire: Phosphor Bronze with 50u  
 " Gold over 100u" Nickel undercoat  
 Temperature: -40°C ~ 70°C  
 Humidity: 10% ~ 90% RH  
 Modular jack: 750 mating cycles  
 Idc block: 200 termination cycles

**ELECTRICAL**  
 Current rating: 1.5 Amps  
 Insulation resistance: 500 MOhm  
 Contact resistance: 20 mOhm  
 DC resistance: 0.1 Ohm  
 Dielectric withstanding voltage: 1000 V

COMMON TOLERANCE		SHEET OF		ALL COPY RIGHTS RESERVED	
CLASS	A	B	SIZE	A4	TITLE
DIMENSION			DIA	mm	<b>DCE</b> DAN-CHIEF ENTERPRISE CO.,LTD. 3013A-F8-C6ABL-1XX
L<=3	±0.05	±0.1	SCALE	1:1	
3<L<=6	±0.05	±0.1	DATE	2004.05.20	
6<L<=16	±0.1	±0.15	DESIGN		
16<L<=30	±0.1	±0.2	DRAWING NO.	K-072-10	DRAWN
30<L<=120	±0.15	±0.3	CHECKED		
120<L<=315	±0.2	±0.5			